

MonoRail

700MOA_ 1.9



GENERAL PRODUCT INFORMATION:



Standard MonoRail bends horizontally to a radius as small as 6" and vertically to a radius as small as 24".

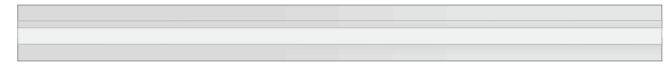

CAUTION - RISK OF FIRE
 This product must be installed in accordance with the applicable installation code by a person familiar with the construction and operation of the product and the hazards involved.
Use minimum 90°C supply conductors.

SAVE THESE INSTRUCTIONS!

NOTE: The MonoRail may be cut to size using a fine tooth saw. If necessary, remove burrs using fine sandpaper.

Bending the MonoRail

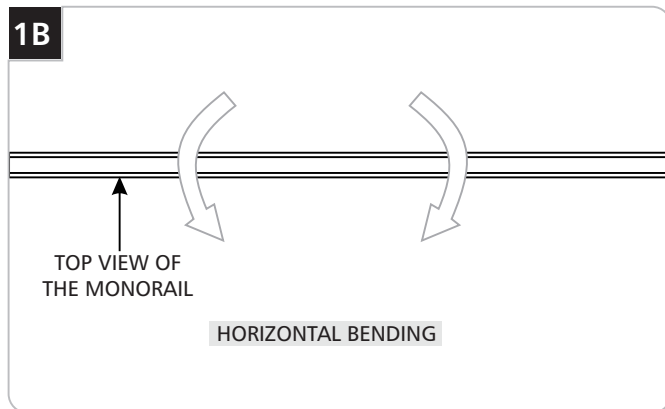
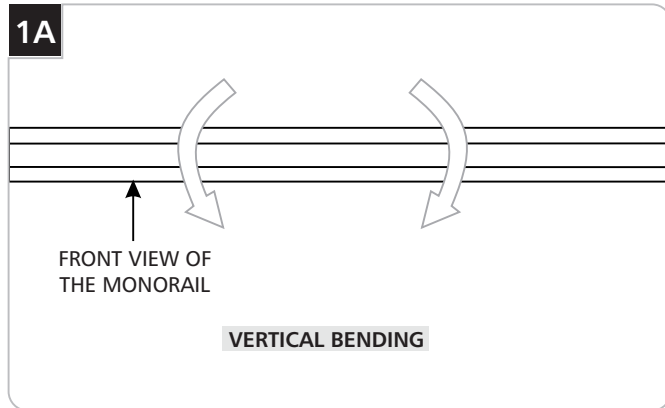

NOTE: There are three techniques to bend the MonoRail horizontally, Plywood Template, Wiremold Pipe Bender, and Freestyle. When bending the MonoRail vertically, only use the wiremold pipe bender technique. MonoRail bends horizontally easier than vertically. When bending the MonoRail vertically, do small bends at the time and avoid bending the MonoRail back which may cause the rail to separate from the insulator.

Plywood Template to Form a Curve or Circle (Horizontal Bend Only)

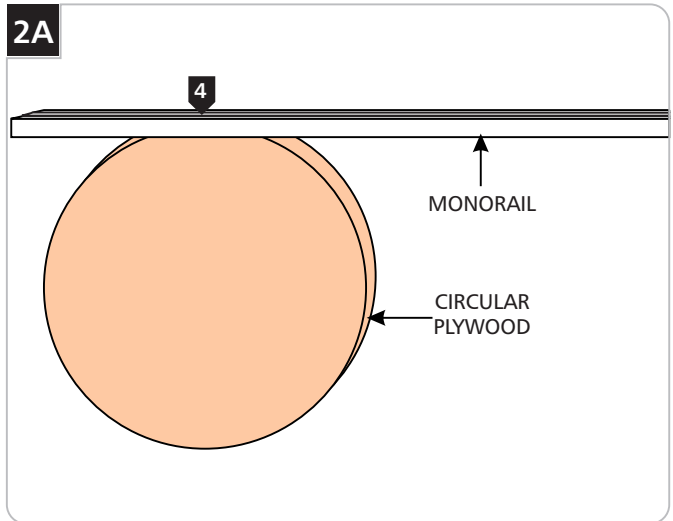

- 1** Determine the radius of the curve or circle.
- 2** On a piece of plywood, draw the curve with the radius approximately 18% tighter than desired (the tighter radius is to account for the MonoRail memory/springback when bending).
Example: For a 20" radius curve, draw a 16.4" radius curve on the plywood (the desired radius has to be multiplied by .82, $20" \times .82 = 16.4"$).
- 3** Cut the pattern from the plywood. Secure the plywood pattern.
- 4** Hold one edge of the MonoRail against the plywood.

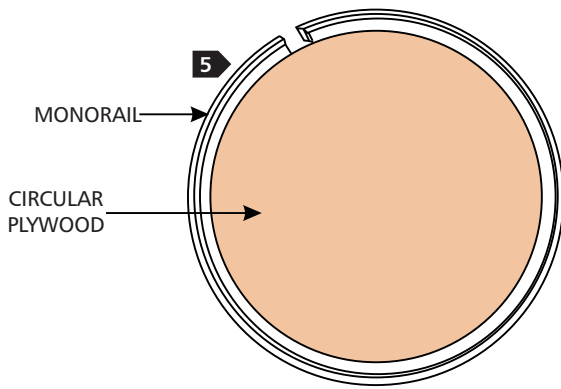
2B

- 5 Start bending the rest of the MonoRail against the circular plywood until the desired curve or circle is achieved.

Wiremold Pipe Bender (Horizontal and Vertical Bend)

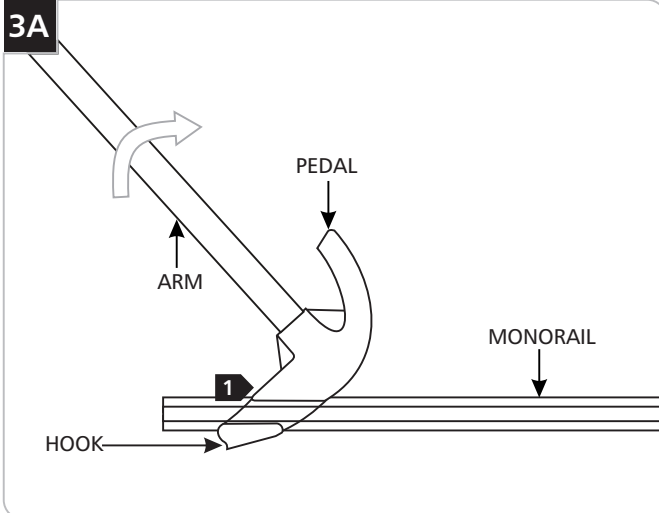

NOTE: The Wiremold pipe bender can be used to create smooth horizontal curve of 90° or less. Avoid stepping on the pedal of the pipe bender which will flatten and damage the MonoRail.

- 1 Feed the MonoRail through the pipe bender hook. Start bending the MonoRail by gently pulling back on the arm of the pipe bender.
- 2 Start with small angle (MAX 10°) to avoid errors in shaping the MonoRail. After each bend unhook and check the MonoRail against the pattern.

Freestyle Bending (Horizontal Bend Only)

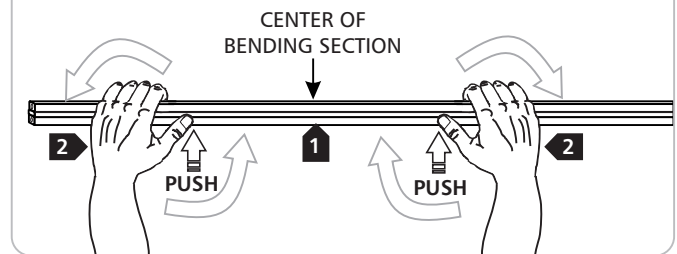
4A

- 1 Choose the center of bending section on the MonoRail. The bending point should be centered between the hands.
- 2 To ensure a smooth curve, begin with hands as far apart as possible, moving the hands closer together as bending progresses. Bend the MonoRail until the desired shape is achieved.

Connecting the MonoRail Sections

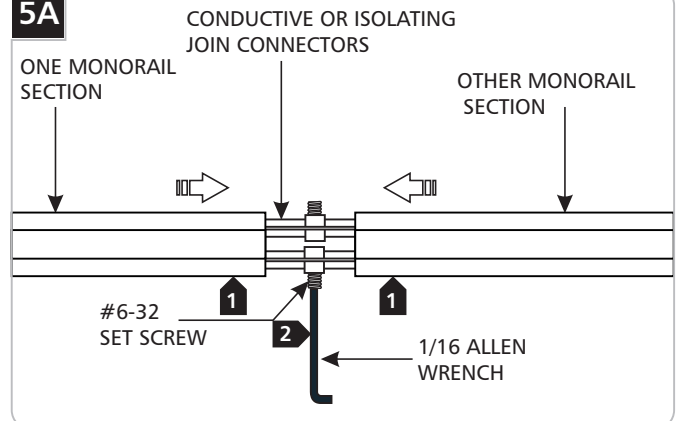
5A

- 1 Push two MonoRail sections completely onto the conductive or isolating join connectors.
- 2 Tighten the #6-32 set screws with the 1/16 Allen wrench provided. Make sure that the set screw connection for conductive connector is tight to avoid heat build up and corrosion. For the isolating connector, tighten the #6-32 set screw firmly to avoid stripping the thread.

 **TECH LIGHTING**

7400 Linder Ave., Skokie, IL 60077
T 847.410.4400 | F 847.410.4500
www.techlighting.com